

Autonics

PHOTOELECTRIC SENSOR BMS SERIES

MANUAL



Thank you very much for selecting Autonics products.
For your safety, please read the following before using.

Caution for your safety

- *Please keep these instructions and review them before using this unit.
- *Please observe the cautions that follow:
- Warning** Serious injury may result if instructions are not followed.
- Caution** Product may be damaged, or injury may result if instructions are not followed.
- *The following is an explanation of the symbols used in the operation manual.
- ⚠: Injury or danger may occur under special conditions.

Warning

- In case of using this unit with machineries(Nuclear power control, medical equipment, vehicle, train, airplane, combustion apparatus, entertainment or safety device etc), it requires installing fail-safe device, or contact us for information on type required.**
It may result in serious damage, fire or human injury.
- Do not disassemble and modify this unit, when it requires. If needs, please contact us.**
It may give an electric shock and cause a fire.

Caution

- This unit shall not be used outdoors.**
It might shorten the life cycle of the product or give an electric shock.
- Do not use this unit in place where there is flammable or explosive gas.**
It may cause a fire or explosion.
- Please observe voltage rating and do not supply AC power.**
It may result in damage to this unit.
- Please check the polarity of power and wrong wiring.**
It may result in damage to this unit.
- Do not use this unit in place where there is vibration or impact.**
It may result in damage to this unit.
- In cleaning the unit, do not use water or an oil-based detergent**
It might cause an electric shock or fire that will result in damage to the product.

Ordering information

BMS 5M - T D T 1 - P	Control output	NPN open collector output
	P	PNP open collector output
Appearance	1	Emitter
	2	Receiver
		Single body type
Output	T	Solid-state output(TR)
Power supply	D	DC power
Detecting type	T	Through-beam
	M	Retroreflective
	D	Diffuse reflective
Detecting distance	M	Unit : m
		Unit : mm
Photoelectric sensor	BMS	Series name

Operation mode

Operation mode	Light ON mode	Dark ON mode
Receiver	Received light	Interrupted light
Operation indicator (LED)	ON	OFF
Output TR	ON	OFF

- The control output TR will be maintained OFF for 0.5 sec. after supplied power in order to prevent malfunction of this photoelectric sensor.
- If the control output terminal is short-circuited or flow beyond rating current, the control signal will not be output normally due protection circuit.

*The above specifications are changeable without notice anytime.

Specification

Type	Through-beam	Retroreflective(Note1)	Diffuse reflective
Model	NPN open collector output BMS5M-TDT	BMS2M-MDT	BMS300-DDT
	PNP open collector output BMS5M-TDT-P	BMS2M-MDT-P	BMS300-DDT-P
Detecting distance	5m	0.1 to 2m	300mm(100×100mm non-glossy white paper)
Detecting target	Opaque materials of Min. φ10mm	Opaque materials of Min. φ60mm	Transparent, Translucent, Opaque materials
Hysteresis	Max. 20% at detecting distance		
Response time	Max. 1ms		
Power supply	12-24VDC ±10%(Ripple P-P:Max. 10%)		
Current consumption	Max. 50mA	Max. 45mA	
Light source	Infrared LED(modulated)		
Sensitivity adjustment	Adjustable VR		
Operation mode	Selectable Light ON, Dark ON by control wire		
Control output	<ul style="list-style-type: none"> NPN open collector output : Load voltage Max. 30VDC, Load current max. 200mA, Residual voltage Max. 1V PNP open collector output : Output voltage Min. (Power supply-2.5)V, Load current Max. 200mA 		
Protecting circuit	Reverse polarity protection, Short-circuit protection		
Indication	<ul style="list-style-type: none"> Operation indicator : Red LED Power indicator : Red LED(BMS5M-TDT1) 		
Connection	Outgoing cable		
Insulation resistance	Min. 20MΩ(500VDC)		
Noise strength	±240V the square wave noise(pulse width:1μs) by the noise simulator		
Dielectric strength	1,000VAC 50/60Hz for 1minute		
Vibration	1.5mm amplitude at frequency of 10 to 55Hz in each of X, Y, Z directions for 2 hours		
Shock	500m/s ² (50G) in X, Y, Z directions for 3 times		
Ambient illumination	Sunlight : Max. 11,000lx, Incandescent lamp : Max. 3,000lx		
Ambient temperature	-10 to +60°C(non-freezing condition), Storage : -25 to +70°C		
Ambient humidity	35 to 85%RH, Storage : 35 to 85%RH		
Material	Case:ABS, Lens:Acryl(Retroreflective:PC)		
Cable	4P, φ5mm, length:2m(Emitter of through-beam type: 2P, φ5mm, length:2m)		
Accessories	Individual	Mirror(MS-2)	
	Common	Mounting bracket, Bolts/nuts, Driver	
Weight	Approx. 180g	Approx. 110g	Approx. 100g
Approval	CE		

* (Note1) The sensing range and the sensing object of the retroreflective sensor are specified with using the MS-2 reflector. The sensing ranges of the retroreflective sensor in the above table are indentified as the possible setting ranges of the MS-2 reflector. The sensor can detect an object under 0.1m apart.

Connection

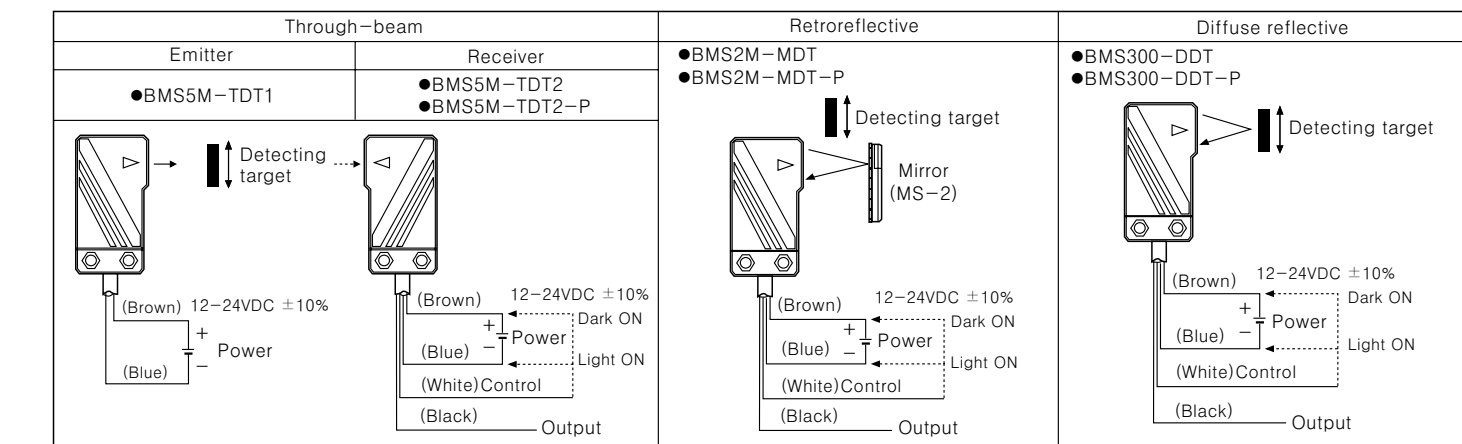

Dimension

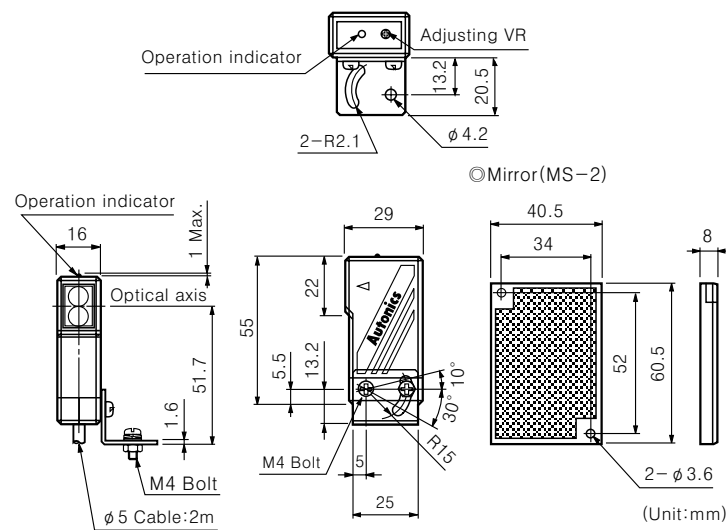

Control output circuit diagram

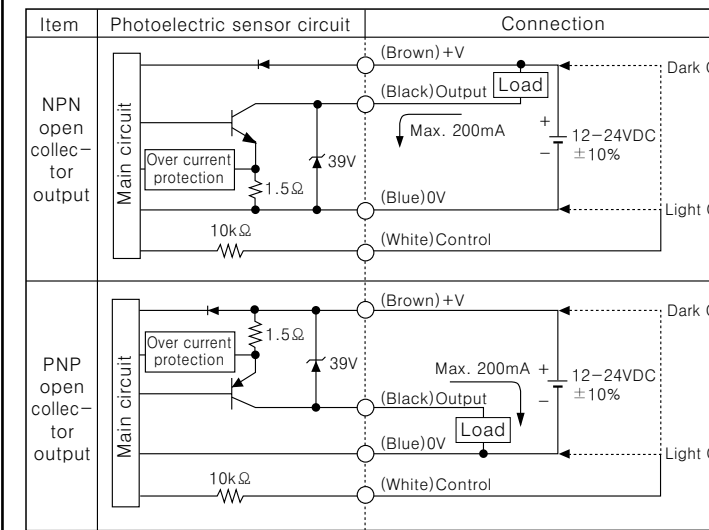

Mounting & Adjustment

Please supply the power to the sensor, after setting the emitter and the receiver in face to face, and then adjust an optical axis and the sensitivity as follow;

Optical axis adjustment

- Through-beam type**
Set the photoelectric sensor in the middle of receiver indicator turns on, as adjusting the receiver or emitter right and left, up and down.
- Retroreflective type**
Install the photoelectric sensor and mirror face to face then fix them in the middle of operation indicator turns on, as adjusting the mirror right and left, up and down
- Diffuse reflective type**
Install the photoelectric sensor and the target then fix it in the middle of operation indicator turns on, as adjusting the photoelectric sensor right and left, up and down.

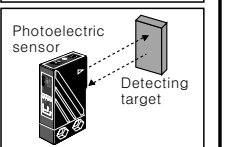
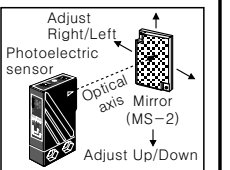
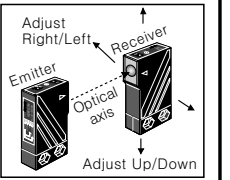

Sensitivity adjustment

- Through-beam type & Retroreflective type**
Fix the adjuster at max. position and then check if the sensor operates normally or not, as passing the target within detecting range of the sensor.
If the sensor does not work normally by noise or external shine, turn the adjuster slowly at position where the sensor works normally.
*If reflectance of target is higher than non-glossy white paper, it might cause malfunction by reflection from the target when the target is near to photoelectric sensor. Therefore put enough space between the target and photoelectric sensor or the surface of target should be installed at an angle of 30° to 45° against optical axis.
- Diffuse reflective type**
Set the target at a position to be detected by the beam, then turn the adjuster till point (a) which the indicator turns on from min. Take the target out of the sensor, then turn the adjuster till point (b) which the indicator turns on, if it does not turn on, max. sensitivity position will be point (a). Set the adjuster in middle of two switching point (a), (b).
*Install the sensor after check the reflectance of background, target, flat part to avoid a malfunction of the sensor.

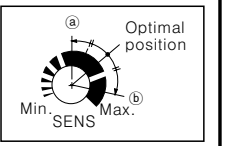
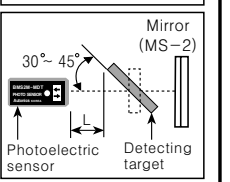

Caution for using

- Intercept a strong source of light as like sunlight, spotlight within inclination angle range of photoelectric sensor.
- The photoelectric sensor may cause malfunction under the fluorescent lamp light, so be sure to use cut-off light with panel.
- When more than 2 sets of Through-beam type sensor are used closely, it might cause interference each other. Be sure to put enough space between them in order to avoid malfunction.
- When more than 2 sets of diffuse reflection types are installed adjacently, it can be occurred malfunction by light beam from the other target. So it must be installed at an enough interval.
- If photoelectric sensor is installed at flat part, it might cause malfunction by reflection light from flat part. Be sure to put space between photoelectric sensor and ground.
- When wire the photoelectric sensor with high voltage line, power line in the same conduit, it may cause malfunction or mechanical trouble.
Therefore please wire separately or use different conduit.
- Avoid installing the unit as following place.
Corrosive gas, oil or dust, strong flux, noise, sunlight, strong alkali, acid.
- In case of connect DC relay as inductive load to output, please remove surges by using diode or varistor.
- The photoelectric sensor cable shall be used as short as possible, because it may cause malfunction by noise through the cable.
- When it is stained by dirt at lens, please clean the lens with dry cloth, but don't use an organic materials such as alkali, acid, chromic acid.
- When use switching power supply as the source of supplying power, F.G terminal shall be good earth ground and condenser for removing noise shall be installed between 0V and F.G terminal.

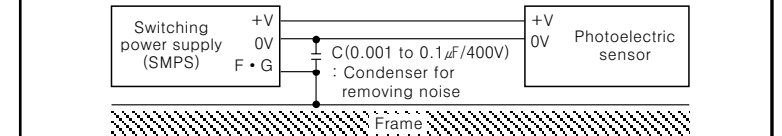

*It may cause malfunction if above instructions are not followed.

Main products

- COUNTER
- TIMER
- TEMPERATURE CONTROLLER
- PANEL METER
- TACHOMETER
- LINE SPEED METER
- DISPLAY UNIT
- PROXIMITY SWITCH
- PHOTOELECTRIC SENSOR
- FIBER OPTIC SENSOR
- PRESSURE SENSOR
- ROTARY ENCODER
- SENSOR CONTROLLER
- POWER CONTROLLER
- STEPPING MOTOR & DRIVER & CONTROLLER

Autonics Corporation
http://www.autonics.net

HEAD QUARTER :
41-5, Yongdang-Ri, Ungsang-Up, Yangsan-Shi, Kyung-Nam, Korea 626-847.

TRADE DEPARTMENT :
511 Ansung B/D, 410-13, Shindolim-Dong, Kuro-Gu, Seoul, Korea 152-070
TEL:82-2-679-6585 / FAX:82-2-679-6556
E-mail : sales@autonics.net

NO20020618-EP-KE-08-0040D