

# Autonics

## PHOTOELECTRIC SENSOR BM SERIES

M A N U A L



Thank you very much for selecting Autonics products.  
For your safety, please read the following before using.

### Caution for your safety

- Please keep these instructions and review them before using this unit.
- Please observe the cautions that follow;
  - Warning** Serious injury may result if instructions are not followed.
  - Caution** Product may be damaged, or injury may result if instructions are not followed.
- The following is an explanation of the symbols used in the operation manual.
  - Injury or danger may occur under special conditions.

### Warning

- In case of using this unit with machineries (Nuclear power control, medical equipment, vehicle, train, airplane, combustion apparatus, entertainment or safety device etc), it requires installing fail-safe device, or contact us for information on type required. It may result in serious damage, fire or human injury.
- Do not disassemble and modify this unit, when it requires. If needs, please contact us. It may give an electric shock and cause a fire.

### Caution

- This unit shall not be used outdoors. It might shorten the life cycle of the product or give an electric shock.
- Do not use this unit in place where there is flammable or explosive gas. It may cause a fire or explosion.
- Please observe voltage rating and do not supply AC power. It may result in damage to this unit.
- Please check the polarity of power and wrong wiring. It may result in damage to this unit.
- Do not use this unit in place where there is vibration or impact. It may result in damage to this unit.
- In cleaning the unit, do not use water or an oil-based detergent. It might cause an electric shock or fire that will result in damage to the product.
- Do not short circuit the load. It may result in damage to the unit.

### Ordering information

BM 3M - T D T □	Appearances	1 Emitter 2 Receiver Single body type
	Output	Solid-state output (Transistor)
	Power supply	DC power
	Detecting type	T Through-beam M Retroreflective D Diffuse reflective
	Detecting distance	M Unit:m Unit:mm
	Photoelectric sensor	BM Series name

\*The above specifications are changeable without notice anytime.

### Specification

Type	Through-beam	Retroreflective	Diffuse reflective
Model	BM3M-TDT	BM1M-MDT	BM200-DDT
Detecting distance	3m	0.1 to 1m	200mm (200×200mm non-glossy white paper)
Detecting target	Opaque materials of min. φ8mm	Opaque materials of min. φ60mm	Transparent, Translucent, Opaque materials
Hysteresis	Max. 10% at detecting distance		
Response time	Max. 3ms		
Power supply	12-24VDC ±10% (Ripple P-P:Max. 10%)		
Current consumption	Max. 45mA	Max. 40mA	
Light source	Infrared LED(modulated)		
Sensitivity adjustment	Fixed	Adjustable VR	
Operation mode	Dark ON		Light ON
Control output	NPN open collector output Load voltage : Max. 30VDC, Load current : Max. 100mA, Residual voltage : Max. 1V		
Protection circuit	Reverse polarity protection		
Indication	Operation indicator:Red LED		
Connection	Outgoing cable		
Insulation resistance	Min. 20MΩ (500VDC)		
Noise strength	±240V the square wave noise(pulse width:1μs) by the noise simulator		
Dielectric strength	1,000VAC 50/60Hz for 1minute		
Vibration	1.5mm amplitude at frequency of 10 to 55Hz in each of X, Y, Z directions for 2 hours		
Shock	500m/s <sup>2</sup> (50G) in X, Y, Z directions for 3 times		
Ambient illumination	Sunlight : Max. 11,000lx, Incandescent lamp : Max. 3,000lx		
Ambient temperature	-10 to +60°C (non-freezing condition), Storage : -25 to +70°C		
Ambient humidity	35 to 85%RH, Storage : 35 to 85%RH		
Material	Case:ABS, Lens:Acryl(Retroreflective:PC)		
Cable	3P, φ4mm, length:2m(Emitter of through-beam type: 2P, φ4mm, length:2m)		
Accessories	Individual Common	Mirror (MS-2)	Driver
Weight	Approx. 170g	Mounting bracket, Bolts/nuts Approx. 105g	Approx. 88g
Approval	CE		

### Connection

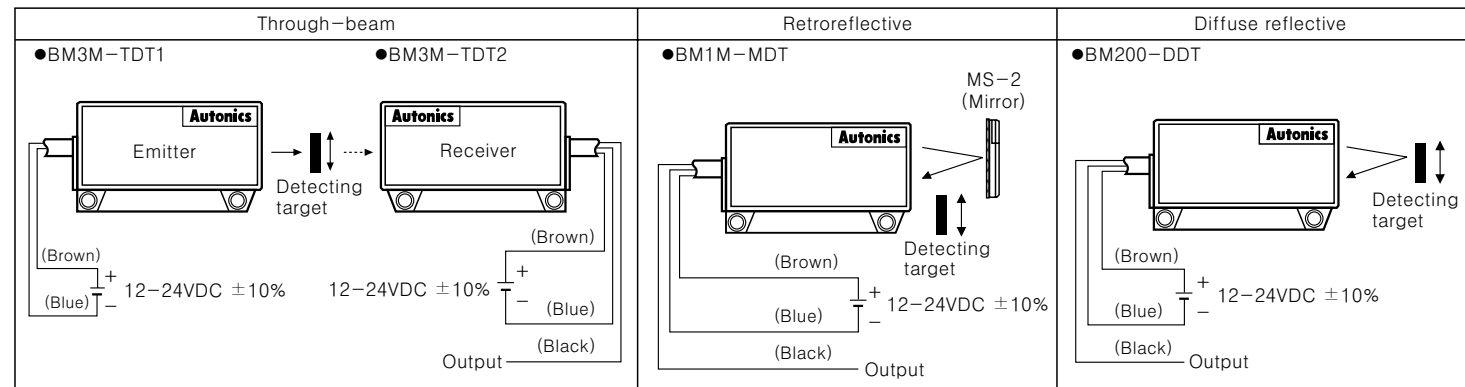

### Dimension

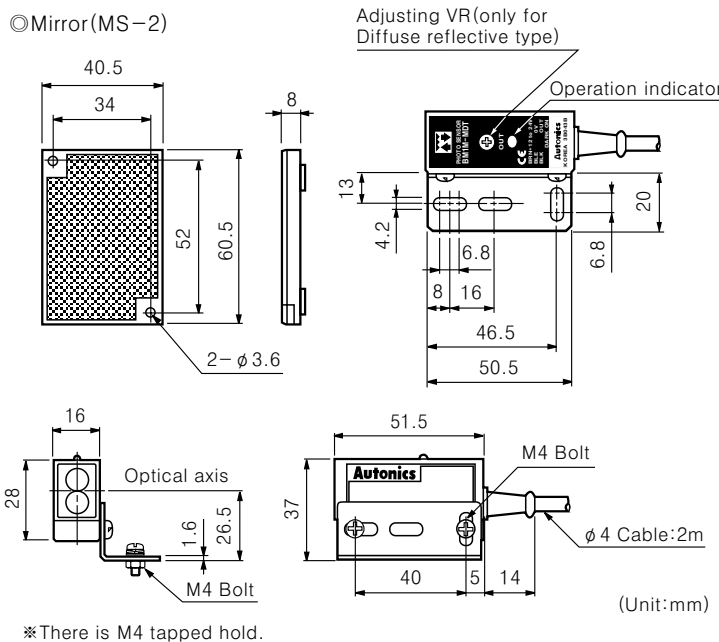

### Operation mode

Operation mode	Light ON mode	Dark ON mode
Receiver operation	Received light: High pulse Interrupted light: Low pulse	High pulse
Operation indicator (LED)	ON: High pulse OFF: Low pulse	High pulse
Output TR	ON: High pulse OFF: Low pulse	High pulse

### Control output circuit diagram

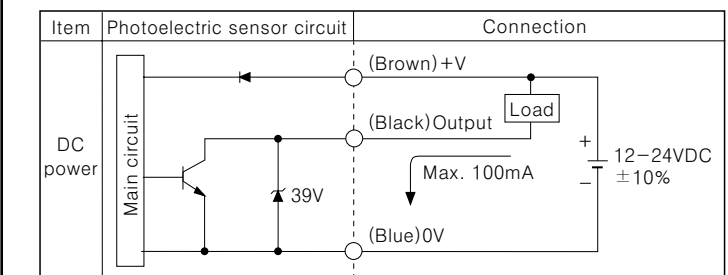

### Mounting & Adjustment

#### Through-beam type

- Supply the power to the photoelectric sensor, after setting the emitter and the receiver in face to face.
- Set the receiver in center of position where indicator turns on, as adjusting the receiver or the emitter right and left, up and down.
- Fix both units tightly after checking that the unit detects the target.

#### Retroreflective type

- Supply the power to the photoelectric sensor, after setting the photoelectric sensor and the mirror (MS-2) in face to face.
  - Set the photoelectric sensor in the position which indicator turns on, as adjusting the mirror or the sensor right and left, up and down.
  - Fix both units tightly after checking that the unit detects the target.
- \*If use more than 2 photoelectric sensors in parallel, the space between them should be more than 30cm.  
\*If reflectance of target is higher than non-glossy white paper, it might cause malfunction by reflection from the target when the target is near to photoelectric sensor. Therefore put enough space between the target and photoelectric sensor or the surface of target should be installed at an angle of 30° to 45° against optical axis.

#### Diffuse reflective type

- Even though the diffuse reflective type is set at max. sensitive position, the sensitivity of the sensor must be adjusted according to the existence of the reflective material in background.
  - Set the target at a position to be detected by the beam, then turn the adjuster until point (a) where the indicator turn on from min. position of the adjuster.
  - Take the target out of the photoelectric sensor, then turn the adjuster until point (b) which the indicator turns on, if the indicator does not turn on, max. sensitivity position will be point (b).
  - Set the adjuster at the middle of two switching point (a), (b).
- \*The detecting distance indicated on specification chart is against 200×200mm of non-glossy white paper. Be sure that it can be different by size, surface and gloss of target.

### Caution for using

- Intercept a strong source of light as like sunlight, spotlight within inclination angle range of photoelectric sensor.
- The photoelectric sensor may cause malfunction under the fluorescent lamp light, so be sure to use cut-off light with panel.
- When more than 2 sets of Through-beam type sensor are used closely, it might cause interference each other. Be sure to put enough space between them in order to avoid malfunction.
- When more than 2 sets of diffuse reflection types are installed adjacently, it can be occurred malfunction by light beam from the other target. So it must be installed at an enough interval.
- If photoelectric sensor is installed at flat part, it might cause malfunction by reflection light from flat part. Be sure to put space between photoelectric sensor and ground.
- When wire the photoelectric sensor with high voltage line, power line in the same conduit, it may cause malfunction or mechanical trouble. Therefore please wire separately or use different conduit.
- Avoid installing the unit as following place.  
Corrosive gas, oil or dust, strong flux, noise, sunlight, strong alkali, acid.
- In case of connect DC relay as inductive load to output, please remove surges by using diode or varistor.
- The photoelectric sensor cable shall be used as short as possible, because it may cause malfunction by noise through the cable.
- When it is stained by dirt at lens, please clean the lens with dry cloth, but don't use an organic materials such as alkali, acid, chromic acid.
- When use switching power supply as the source of supplying power, F.G terminal shall be good earth ground and condenser for removing noise shall be installed between 0V and F.G terminal.

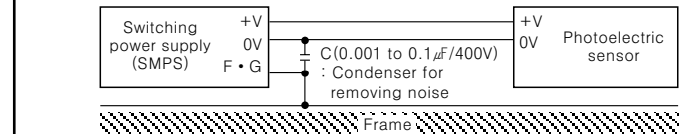

\*It may cause malfunction if above instructions are not followed.

### Main products

- COUNTER
- TIMER
- TEMPERATURE CONTROLLER
- PANEL METER
- TACHOMETER
- LINE SPEED METER
- DISPLAY UNIT
- PROXIMITY SWITCH
- PHOTOELECTRIC SENSOR
- FIBER OPTIC SENSOR
- PRESSURE SENSOR
- ROTARY ENCODER
- SENSOR CONTROLLER
- POWER CONTROLLER
- STEPPING MOTOR & DRIVER & CONTROLLER

**Autonics** Corporation  
<http://www.autonics.net>

HEAD QUARTER :  
41-5, Yongdang-Ri, Uingsang-Up, Yangsan-Shi, Kyung-Nam, Korea 626-847.  
TRADE DEPARTMENT :  
511 Ansong B/D, 410-13, Shindolim-Dong, Kuro-Gu, Seoul, Korea 152-070  
TEL:82-2-679-6585 / FAX:82-2-679-6556  
E-mail : sales@autonics.net

NO20020618-EP-KE-08-0030D